

SNES series

Ø130mm Explosion Proof Warning/ Signal Lights with Siren Buzzer

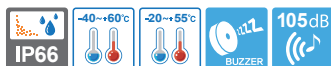

Siren buzzer sound output of Max 105dB



SNESLR



SNESL

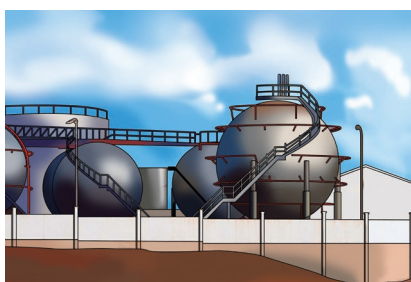

Flameproof warning/ signal lights applied in an areas where potentially explosive materials may linger as shown in the refinery image above.



Common Specifications(SNESLR/ SNESL/ SNES-S/ SNES)

- Light weight and compact explosion proof warning lights with a siren buzzer
- A variety of light source selections from bulb, LED, and xenon lamp
- Aluminum housing provides excellent durability
- Fully enclosed structure with protection rating of IP66
- Integrated housing and terminal box model
- Sound type and sound volume : Siren buzzer- Max 105dB at 1m/ 7 sounds buzzer, Max 95dB at 1m
- User selected built-in buzzer with 7 sound patterns available upon request
- Housing standard color : MUNSELL No. 7.5BG 7/2
- Cable entry : 1/2" NPT
- Materials : Lens-Tempered glass, Inner lens-PC, housing-Al, Protection cage-ST316L, Reflector for LED type-PC/ Reflector for bulb type-Heat resistant ABS
- Certificates : IECEx, ATEX, NEPSI, KCs, CCS, CCC(F), TIIS
- Protection rating :
 - ATEX - Ex d IIC T6 Gb , Ex db op is IIC T6 Gb (with LED)
 - IECEX - Ex db IIC T6 Gb, Ex db op is IIC T6 Gb (with LED)
 - KCs - Ex d IIB+H2 IP66 T6
 - NEPSI, CCC - Ex d IIC T6 Gb
 - TIIS - IIC T6 Gb (SNESLR DC12/24V, AC110V only)
- Ambient operating temperature : $-40^{\circ}\text{C} \leq \text{Tamb} \leq +60^{\circ}\text{C}$
 $-40^{\circ}\text{C} \leq \text{Tamb} \leq +55^{\circ}\text{C}$ (KCs)
 $-20^{\circ}\text{C} \leq \text{Tamb} \leq +55^{\circ}\text{C}$ (TIIS, SNEL only)



SNESLR LED Revolving Warning Light with Siren Buzzer

- Excellent omni-directional visibility with LED light collecting system and special multifaceted reflector
- Revolving speed : 120-140RPM

Model number	Voltage	Current	Sound pattern/ dB	Certificates	Weight	Color
SNESLR	DC12V	0.485A	• Warning sound(Buzzer) : 105dB • 7 sounds(Buzzer): 95dB		3.60kg	• R-Red • A-Amber • G-Green • B-Blue
	DC24V	0.411A			3.60kg	
	AC110V	0.111A			4.30kg	
	AC220V	0.055A			4.30kg	



SNESL LED Steady/ Flashing Signal Light with Siren Buzzer

- Long-lasting high intensity LED light source
- Suitable for applications where bulb replacement is hard
- Built in switch for steady/flashing selection
- Flashing rate : 60-80 flashes/min

Model number	Voltage	Current	Sound pattern/ dB	Certificates	Weight	Color
SNESL	DC12V	0.432A	• Warning sound(Buzzer) : 105dB • 7 sounds(Buzzer): 95dB		3.65kg	• R-Red • A-Amber • G-Green • B-Blue
	DC24V	0.377A			3.65kg	
	AC110V	0.111A			4.30kg	
	AC220V	0.055A			4.30kg	



Customization

- Explosion proof cable gland attached type available (Standard type does not come with explosion proof cable gland)
- Customized 2 way cable entries
- Customized cable entry (M20×1.5) available
- ATEX certified type
- IECEx certified type
- Customized built-in buzzer with 7 sound patterns available

SNES series

Ø130mm Explosion Proof Warning/ Signal Lights with Siren Buzzer

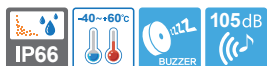

Siren buzzer sound output of Max 105dB



SNES-S

SNES-S Xenon Strobe Signal Light with Siren Buzzer

- Lamp connector fastening structure allows for convenient lamp replacement
- Excellent long-distance visibility with strong flashing signal diffusion
- Flashing rate : 60-80 flashes/min

Model number	Voltage	Current	Bulb			Sound pattern/dB	Certificates	Weight	Color	
			Spec	Standard	Parts no					
SNES-S	DC12V	0.655A	200V -550V	EUB0641 -1A(G) U Type	48	<ul style="list-style-type: none"> • Warning sounds(Buzzer) : 105dB • 7 sounds(Buzzer) : 95dB 		3.60kg	<ul style="list-style-type: none"> • R-Red • A-Amber • G-Green • B-Blue 	
	DC24V	0.500A								3.60kg
	AC110V	0.104A								4.25kg
	AC220V	0.066A								4.25kg

SNES Bulb Revolving Warning Light

- Excellent signal light diffusion effect with multi-faced reflector
- Revolving speed : 120-140RPM

Model number	Voltage	Current	Bulb			Sound pattern/dB	Certificates	Weight	Color	
			Spec	Standard	Parts no					
SNES	DC12V	1.766A	12V15W	G23 15S	17	<ul style="list-style-type: none"> • Warning sounds(Buzzer) : 105dB • 7 sounds(Buzzer) : 95dB 		3.70kg	<ul style="list-style-type: none"> • R-Red • A-Amber • G-Green • B-Blue 	
	DC24V	1.044A	24V15W	G23 15S	18					3.70kg
	AC110V	0.288A	12V15W	G23 15S	17					4.40kg
	AC220V	0.144A	12V15W	G23 15S	17					4.40kg



Technical Diagram

(Units : mm)



SNES

SNESLR/ SNESL/ SNES-S/ SNES

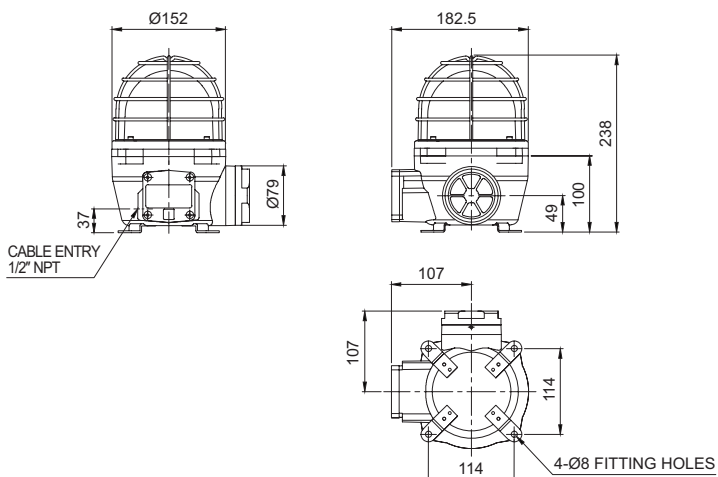

Ordering Specification

SNES	-	220	-	R
[Model number]		[Voltage]		[Color]
<ul style="list-style-type: none"> • SNESLR • SNESL • SNES-S • SNES 		<ul style="list-style-type: none"> • 12-DC12V • 24-DC24V • 110-AC110V • 220-AC220V 		<ul style="list-style-type: none"> • R-Red • A-Amber • G-Green • B-Blue

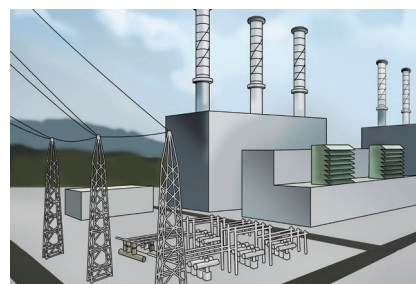

Flameproof warning/ signal lights applied in dust explosion areas such as coal dust shown in thermoelectric power plant image above.